

CUSTOMER APPROVAL	IF NOT RETURNED TO FGFT BY THE DATE INDICATED BELOW, WE WILL PROCEED WITH FABRICATION AS PER THE DRAWING
SALES SIGNATURE:	
CUSTOMER SIGNATURE:	
DATE:	
RETURN TO FGFT BY:	DATE: AUGUST 1, 2023
REVIEWED BY:	
REVIEW DATE:	
ACCEPTED AS IS:	<input type="checkbox"/>
ACCEPTED WITH REVISION NOTED:	<input type="checkbox"/>
REVISE AS NOTED AND RE-SUBMIT:	<input type="checkbox"/>

BODY TYPE: EXTRUDED ALUMINUM
TANK SIDE: WET SIDE

DOC. NO. : E018-1 DRAWING TEMPLATE
REV. C 2017-02-05

SPECIFICATION

- CHASSIS:**
 -FREIGHTLINER M2 112 SBA REGULAR CAB
 -47,000 LB GVWR; 16,000 LB FRONT / 31,000 LB REAR
 -DIESEL ENGINE, CUMMINS L9 450EV HP
 -AUTOMATIC TRANSMISSION, ALLISON 3000 EVS
 -CHASSIS SUPPLIED ANTI ROLL STABILITY
- PUMP:**
 -HALE SIDEKICK 500GPM APS
 -500 USGPM (1895 LPM) (415 IGPM) AT 150PSI
 -THIRD PARTY CERTIFICATION MEETING NFPA 1901-2016 EDITION
- PLUMBING AND PIPING:**
 - 1 x 5" SUCTION, (1)ROAD
 - 1 x 2 1/2" GATED SUCTION, (1)ROAD
 - 2 x 1 1/2" HOSE BED PRECONNECT
 - 2 x 2 1/2" DISCHARGE, (2)ROAD
 - 1 x 4" STORZ EXTERNAL TANK FILL FIREMAN'S FRIEND, (1)REAR
 - 3" TANK TO PUMP - AIR
 - 2" TANK FILL
- TANK:**
 -2040 USG (1700 IG) POLY WATER TANK
- BODY:**
 -WET SIDE FIRE TANKER, EXTRUDED ALUMINUM LOW/LOW
 -BODY UNDERCOATING CORASHIELD
- EMERGENCY EQUIPMENT/ACCESSORIES:**
 - LIGHT BAR 56" LED
 - SIREN
 - 1 x 100W SPEAKER
 - 2 x FLOOD LIGHTS
 - 2 x REAR BEACONS RED / BLUE
 - 2 x GRILLE LIGHTS
 - 4 x SIDE LOWER WARNING RED
 - 2 x REAR LOWER WARNING LIGHTS RED
 - 6 x SCENE LIGHTS
 - 6 x GROUND LIGHTS
 - AIR CHARGING PROVISION
 - BATTERY CHARGING PROVISION
 - ANTENNA MOUNT
 - (2) 6" x 10' SUCTION HOSE
 - (1) 6" STRAINER BARREL KOCHEK
- MODEL:**
 WHELEN JUSTICE 56"
 WHELEN CEN COM
 SAPHIRE W/MIC
 WHELEN SA315P
 DTI 010Wx6 LED 12V
 WHELEN L31HRFN LED
 WHELEN 600 LED
 WHELEN 600 LED
 WHELEN 600 LED
 WHELEN M9LZC LED
 LUMA BAR H20-12"
 KUSSMAUL CHEIF SERIES

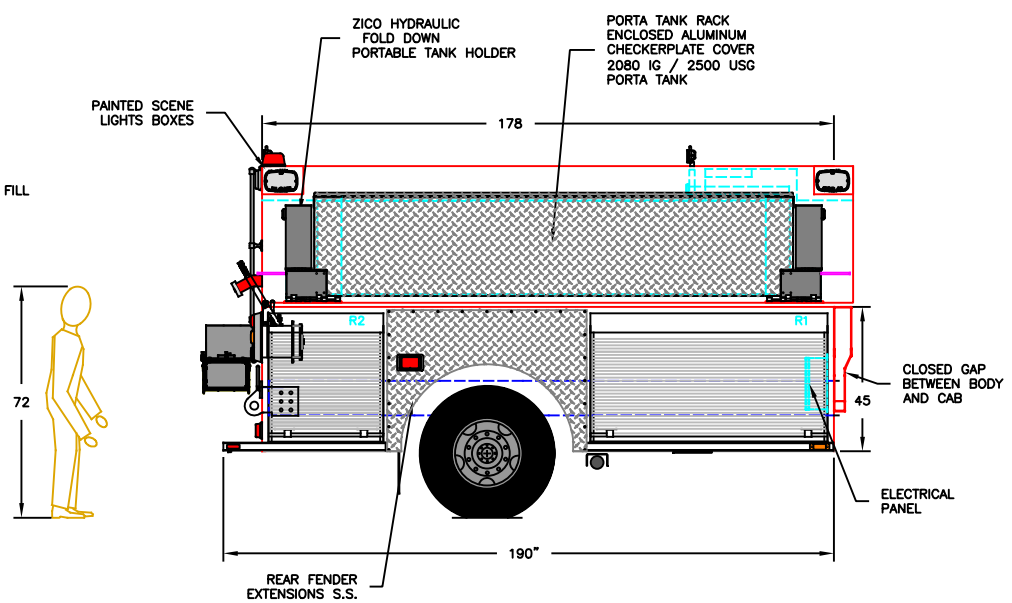
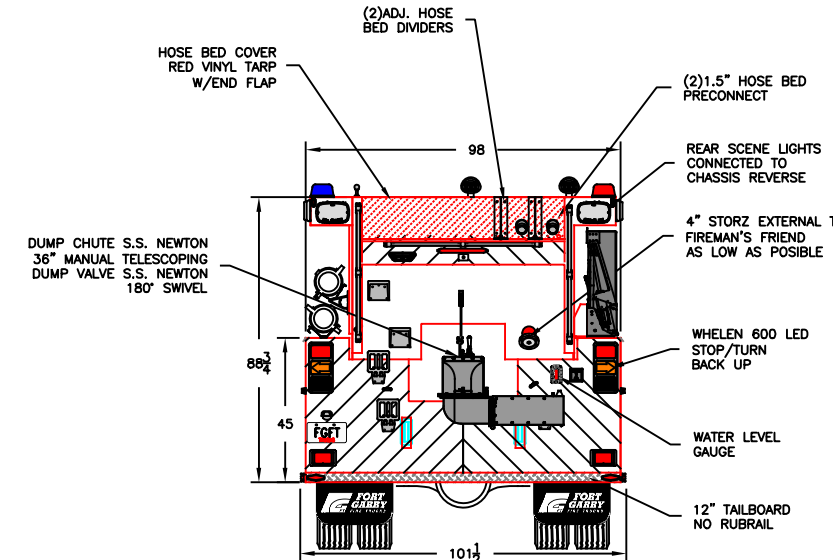
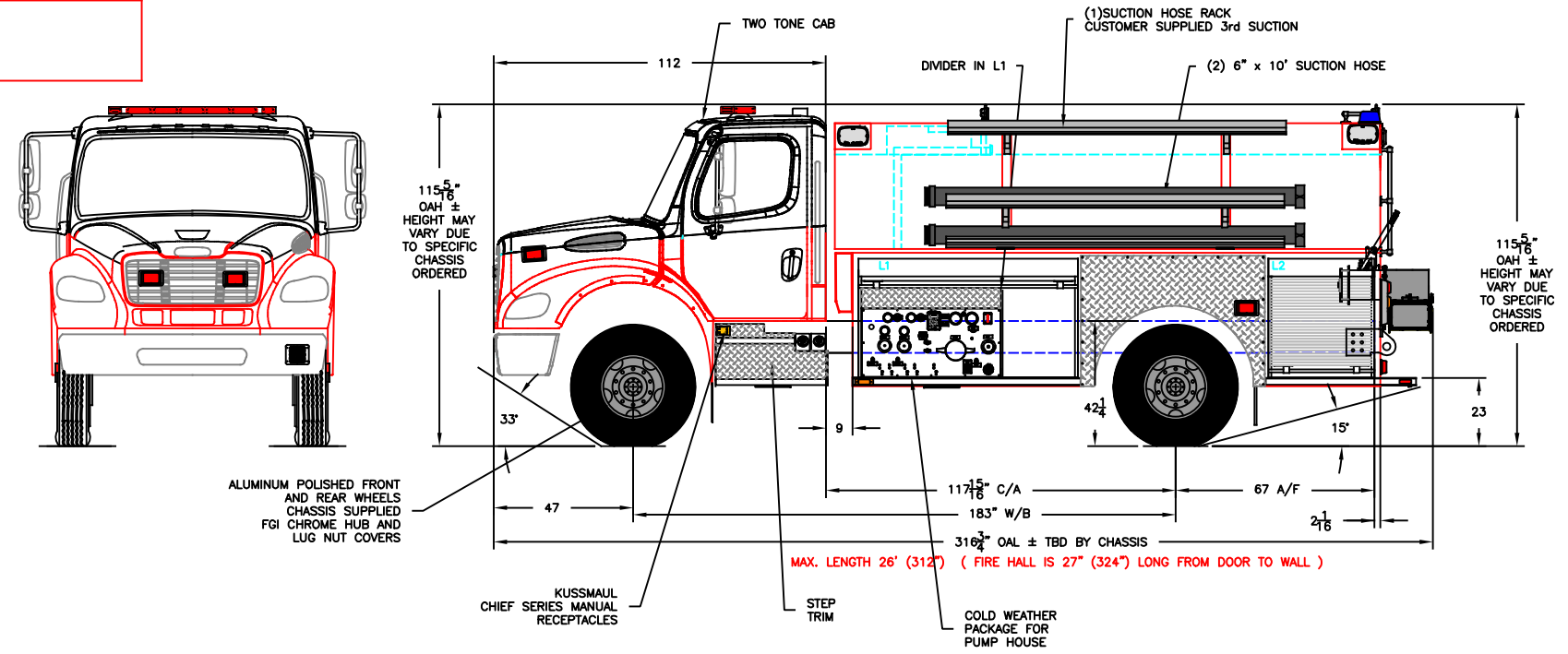

J	REMOVED MANUAL AIR INLET	SP	25 JULY 2023
I	PPM	SP	24 JULY 2023
H	UPDATED TERRI NOTES	SP	29 MAY 2023
G	CUSTOMER SIGN OFF DRAWING	TV	24 JAN 23023
F	PRECONNECTS 1.5"	TV	20 JAN 2023
E	CRM DRAWING	TV	07 DEC 2022
D	REVISED DRAVING -HALL DIM 27'	TV	09 NOV 2022
C	REVISED DRAVING - GAP 9"	TV	08 NOV 2022
B	CHANGED-FREIGHTLINER CHASSIS	TV	31 OCT 2022
A	QUOTE DRAWING	TV	22 JUN 2022
REV	DESCRIPTION OF CHANGE	BY	DATE

FORT GARRY
 FIRE TRUCKS
 WWW.FGFT.COM
 WINNIPEG, MANITOBA, CANADA 1-800-565-3473

DESCRIPTION:	MORRISVILLE F.D.		
SCALE:	1:55	DWG. BY:	TV
		CHK. BY:	

MODEL:	AFT17H2S	SHEET:	1 OF 1
DATE:	22 JUN 2022	DWG. NO. :	J0418

1. THE DRAWING IS FOR REFERENCE PURPOSE, ONLY. THE DRAWING MAY OR MAY NOT SHOW ALL ITEMS AS DESCRIBED IN THE WRITTEN DETAILED SPECIFICATION.
2. INCLUSION OF AN ITEM ON THE DRAWING DOES NOT CONSTITUTE INCLUSION OF THAT ITEM WITH THE FINAL DELIVERY OF THE UNIT. SPECIFICATION SHALL BE FINAL AUTHORITY TO BE DETERMINED WHAT IS SUPPLIED ON THE APPARATUS.
3. THE EFFECTIVE DOOR OPENING FOR ROLLUP DOORS WILL BE REDUCED APPROX. 10" IN HEIGHT, 2" IN DEPTH AND 2" IN WIDTH FROM SHOWN FRAME OPENINGS AND 2" IN HEIGHT, 3" IN DEPTH AND UP TO 4" IN WIDTH FOR PAN DOORS. DIMENSIONS TOLERANCE ± 1/4"
4. PUMP RATING AND TANK CAPACITY ARE SHOWN AS NOMINAL VALUES. THE ACTUAL VALUES MAY VARY.
5. CHASSIS GVWR SHOWN IS THE MINIMUM REQUIRED FOR STANDARD BODY DEPENDING OF OPTIONS, GVWR MAY NEED TO BE INCREASED.
6. COMMERCIAL OEM CAB STEPS MAY NOT MEET ULC STANDARD. SELECT CUSTOM STEPS WHEN REQUIRED.
7. OVERALL HEIGHT IS IN LOADED CONDITION, UNLOADED HEIGHT MAY BE 4" ABOVE HEIGHT SHOWN. AFTER TRUCK IS COMPLETED ADDITIONAL STEPS MAY BE REQUIRED TO MEET THE STANDARD.
8. DIMENSIONS SHOWN ARE APPROXIMATE AND ARE SUBJECT TO CHANGE AS MAY BE FOUND NECESSARY DURING DESIGN. DO NOT SCALE DRAWING.
9. MINOR DETAILS AND REFLECTIVE STRIPING ARE NOT SHOWN.

THIS DRAWING IS PROPERTY OF FORT GARRY FIRE TRUCKS LTD (FGFT) AND MUST NOT BE COPIED OR REPRODUCED IN WHOLE OR IN PART, BY ANY METHOD WHATSOEVER, WITHOUT AUTHORIZATION OF FGFT.